

Name: _____

Foundation Unit 8 topic test

Date:

Time: 50 minutes

Total marks available: 46

Total marks achieved: _____

Questions

Q1.

Write down a suitable metric unit for measuring

(a) the weight of a banana,

.....

(1)

(b) the volume of water in a fish tank,

.....

(1)

(c) the length of a lorry.

.....

(1)

(Total for Question is 3 marks)

Q2.

The shaded shape is drawn on a grid of centimetre squares.

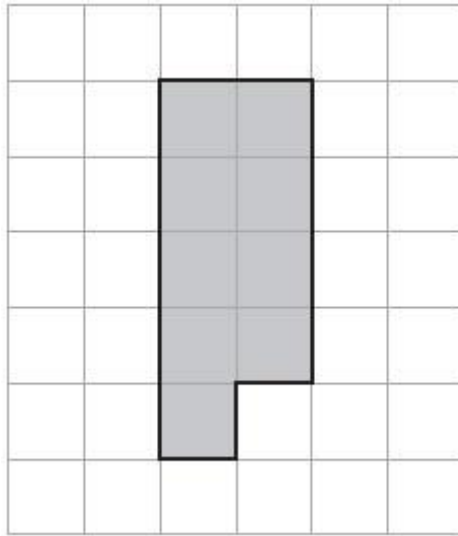

(a) Find the perimeter of the shaded shape.

.....
(2)

(b) On the grid below, draw a square with the same area as the shaded shape.

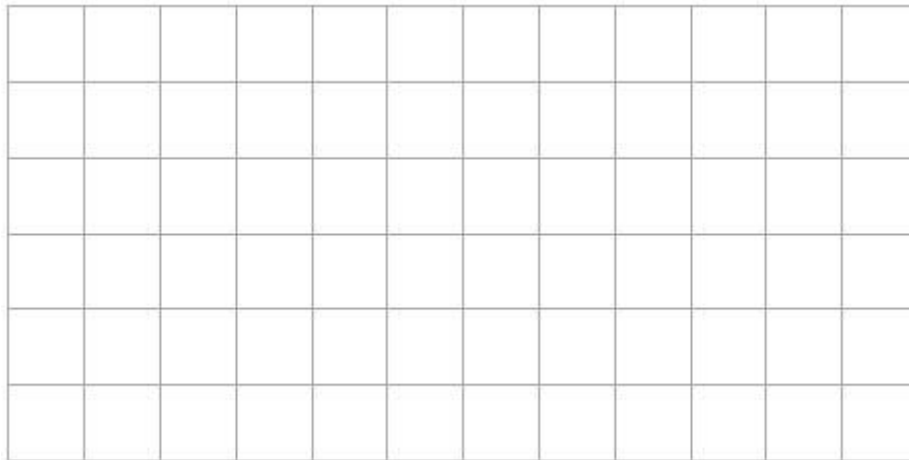

(1)

(Total for Question is 3 marks)

Q3.

Change 530 centimetres into metres.

..... metres
(Total for question is 1 mark)

Q4.

There are 1.5 litres of water in a bottle.

There are 250 millilitres of water in another bottle.

Work out the total amount of water in the two bottles.

.....
(Total for question is 3 marks)

Q5.

Here is a cuboid.

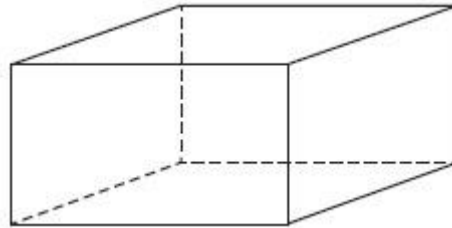

The following sentences are about cuboids.

Complete each sentence by writing the correct number in the gap.

- (a) (i) A cuboid has faces.
- (ii) A cuboid has edges.
- (iii) A cuboid has vertices.

(3)

Here is a different cuboid.

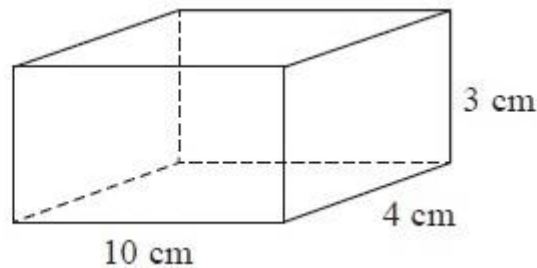

Diagram **NOT**
accurately drawn

- (b) Work out the volume of the cuboid.

..... cm³

(2)

(Total for Question is 5 marks)

Q6.

Here is a square-based pyramid.

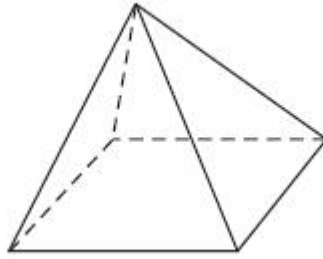

(i) How many faces does the pyramid have?

.....
(1)

(ii) How many edges does the pyramid have?

.....
(1)

(Total for question = 2 marks)

Q7.

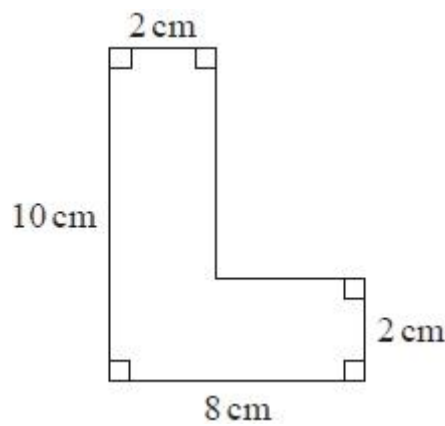

Work out the area of the shape.

..... cm²
(Total for question is 2 marks)

Q8.

The diagram shows a triangular prism.

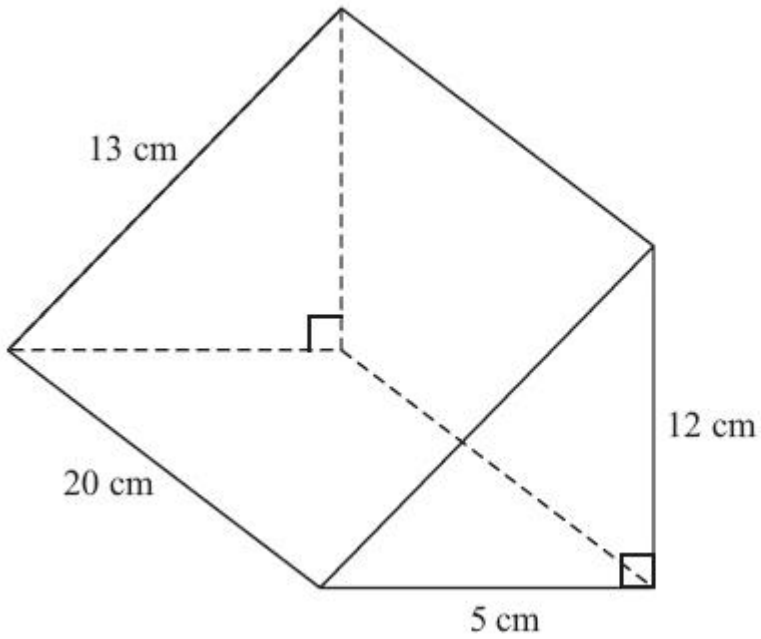

Diagram **NOT** accurately drawn

Work out the total surface area of the prism.

..... cm²

(Total for Question is 3 marks)

Q9.

Here is a diagram of Jim's garden.

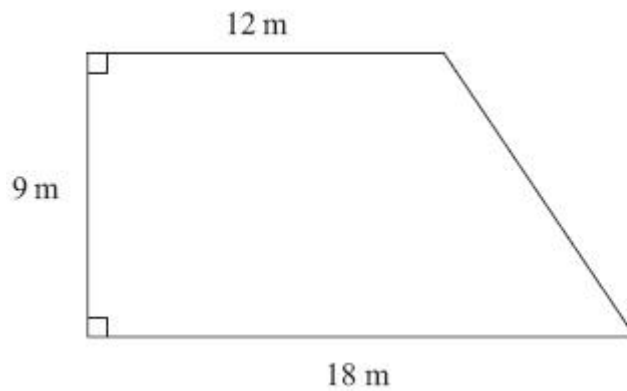

Diagram **NOT**
accurately drawn

Jim wants to cover his garden with grass seed to make a lawn.

Grass seed is sold in bags.

There is enough grass seed in each bag to cover 20 m^2 of garden.

Each bag of grass seed costs £4.99

Work out the least cost of putting grass seed on Jim's garden.

£.....

(Total for Question is 4 marks)

Q10.

Carpet tiles are going to be used to cover a floor.

The floor is a 1200mm by 1000mm rectangle.
Each carpet tile is a 40cm by 30cm rectangle.

Exactly 10 carpet tiles can be used to cover the floor completely.

Show in a labelled sketch how this can be done.

(Total for question = 3 marks)

Q11.

Here is a solid cuboid.

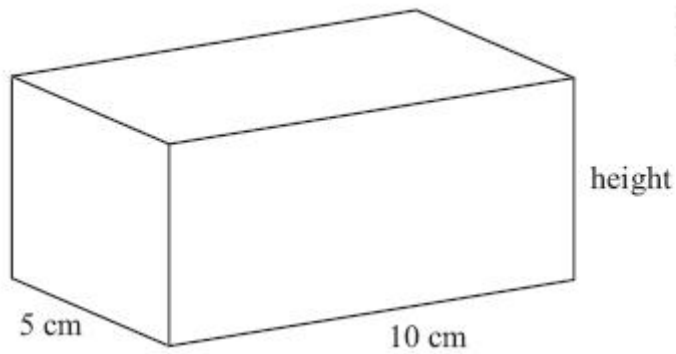

Diagram **NOT**
accurately drawn

The cuboid has a width of 5 cm and a length of 10 cm.
The cuboid has a total surface area of 280 cm^2 .

Work out the height of the cuboid.

..... cm

(Total for Question is 4 marks)

Q12.

* Marc drives a truck.
The truck pulls a container.
The container is a cuboid 10 m by 4 m by 5 m.

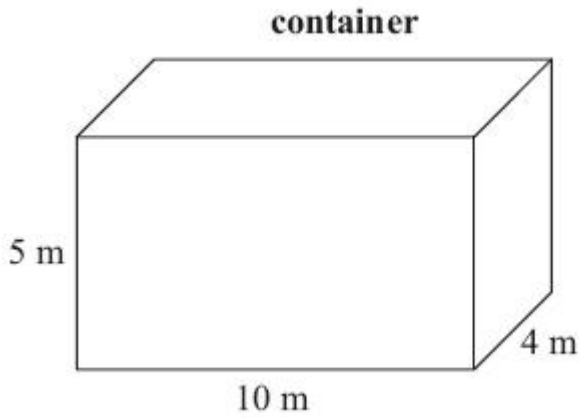
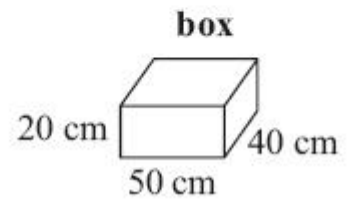

Diagram **NOT**
accurately drawn



Marc fills the container with boxes.
Each box is a cuboid 50 cm by 40 cm by 20 cm.

Show that Marc can put no more than 5000 boxes into the container.

(Total for Question is 4 marks)

Q13.

A pattern is made using identical rectangular tiles.

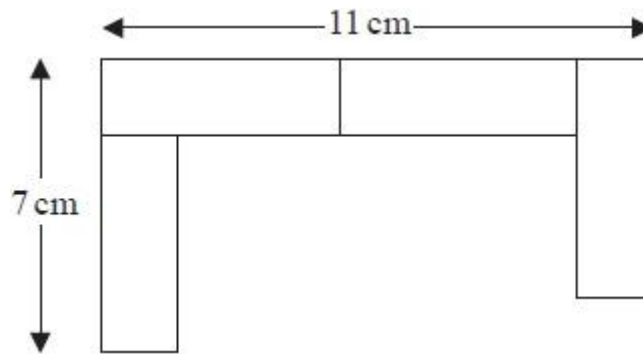

Find the total area of the pattern.

..... cm²

(Total for question is 4 marks)

Q14.

The diagram shows a sand pit.
The sand pit is in the shape of a cuboid.

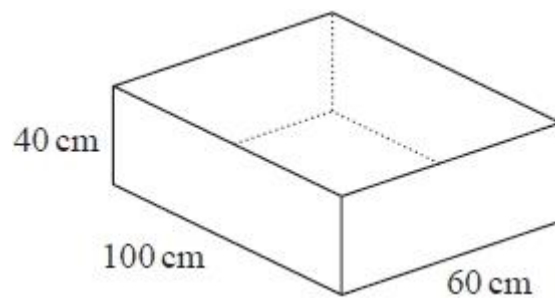

Sally wants to fill the sand pit with sand.
A bag of sand costs £2.50
There are 8 litres of sand in each bag.

Sally

"The sand will cost less than £70"

Show that Sally is wrong.

(Total for question is 5 marks)

Examiner's Report

Q1.

All three parts of this question were answered very well. Incorrect answers were often the result of candidates giving an imperial unit rather than a metric unit, with the most common ones being pounds in part (a), gallons in part (b) and feet in part (c).

Q2.

Counting the number of centimetres on the perimeter proved a challenge for many with the bottom of the shape causing the most problems. A significant number of candidates failed to give the units of cm with their answer, this was frequently omitted or else the wrong units, eg. cm^2 were given. A common incorrect answer from the confusion of area with perimeter was 9 cm^2 . In part (b) a significant number of candidates drew a shape other than a square with an area of 9 cm^2 or drew a shape with an area of 14 cm^2 , again confusing area with perimeter. Others drew a square of the wrong area.

Q3.

No Examiner's Report available for this question

Q4.

No Examiner's Report available for this question

Q5.

Candidates were rarely successful with all parts of (a) with errors appearing to mix up the terms as well as suggesting miscounting. Edges and vertices appeared to be the most commonly interchanged.

In (b), where the correct method for volume was given, some candidates made arithmetic errors with their calculation of $3 \times 4 \times 10$. When the correct method was not given, many attempted to add the 3 given lengths or find the area of a single face or complete surface area.

Q6.

No Examiner's Report available for this question

Q7.

No Examiner's Report available for this question

Q8.

Over two thirds of candidates gained no marks on this question with less than 5% giving a fully correct response. Most candidates did not display knowledge of surface area but instead set about finding the combined length of the edges or simply multiplied three or four of the given numbers together. When candidates did appreciate the need to find areas they often forgot to divide by 2 when finding the area of one of the triangular ends. The sloping face of 260cm^2 was often found and added to a single value of 60. The most successful candidates showed well organised working labelling the different parts of their area calculations with names or diagrams of the shapes involved.

Q9.

Very few candidates used the given formula for the area of a trapezium to find the area of the garden, most choosing instead to find the sum or difference of the areas of a rectangle and triangle. Unfortunately, far too often, the area of the triangle was incorrect, usually simply 54 (6×9). Candidates who found the correct area usually went on to complete the solution correctly, although multiplication of £4.99 by 6 or 7 was often strewn with error. Some lost the final accuracy mark for rounding 7×4.99 to 7×5 and deducting the wrong number of pence, usually 5p not 7p.

Q10.

No Examiner's Report available for this question

Q11.

This was almost always treated as if the 280 was volume. Some appeared to recognise that it wasn't volume and they took the area from 280, but then reverted to volume. Some thought that the height must be the same as the width and gave the answer 5 cm. Very few correct answers.

Q12.

Very few candidates were able to show a clear set of steps starting with the information in the diagram and leading to the conclusion of 5000 being the maximum number of boxes that could fit into the container. Most candidates were only achieving 1 or 2 marks. Where candidates achieved M2 this was usually for correctly calculating a volume and showing that they could convert 5m, 10m or 4m to centimetres. Where candidates only achieved M1 this was usually for correctly calculating a volume.

Common errors included the use of incorrect conversion facts $1\text{m}=10\text{cm}$ or $1\text{m}=1000\text{cm}$, finding the surface areas or just adding the side lengths.

Candidates often tried to fix their calculations to get 5000 or did not realise that 5000 was correct and wrote a contradictory statement, however, they did realise that they needed to show working out and not just offer a worded answer. Many candidates were unaware of the need to convert all the measure to the same unit hence failed to gain the second M1 for division as their values were the wrong way round.

Q13.

No Examiner's Report available for this question

Q14.

No Examiner's Report available for this question

Mark Scheme

Q1.

	Working	Answer	Mark	Notes
(a)		grams or kilograms	1	B1 for grams or kilograms
(b)		litres	1	B1 for litres, accept any cubic unit
(c)		metres	1	B1 for metres, accept millimetres

Q2.

	Working	Answer	Mark	Notes
(a)		14 cm	2	B1 for 14 cao B1 (indep) for cm
(b)		3 by 3 square	1	B1 cao

Q3.

Paper 1MA1: 1F			
Question	Working	Answer	Notes
		5.3(0)	B1 cao

Q4.

Paper 1MA1:3F			
Question	Working	Answer	Notes
		1.75l or 1750 ml	B1 for knowledge of 1 litre is 1000 millilitres P1 for adding their two amounts C1 for 1.75l or 1750 ml (must include units)

Q5.

PAPER: IMA0 1F				
Question	Working	Answer	Mark	Notes
(a)(i)		6	3	B1 cao
		12		B1 cao
(ii)		8		B1 cao
(iii)				
(b)		120	2	M1 $10 \times 3 \times 4$ A1 cao

Q6.

Question	Working	Answer	Notes
i		5	B1
ii		8	B1

Q7.

Paper 1MA1: 1F			
Question	Working	Answer	Notes
		32	M1 for method to find area of any one rectangle A1 cao

Q8.

Question	Working	Answer	Mark	Notes
	<p>Triangular ends $\frac{1}{2} \times 5 \times 12 = 30$ $\frac{1}{2} \times 5 \times 12 = 30$</p> <p>Base $20 \times 5 = 100$</p> <p>Vertical face $20 \times 12 = 240$</p> <p>Slant face $20 \times 13 = 260$</p> <p>Total area $= 30 + 30 + 100 + 240 + 260$ OR $(5 + 12 + 13) \times 20 + 2 \times \frac{1}{2} \times 5 \times 12$</p>	660	3	<p>M1 for area of one face $\frac{1}{2} \times 5 \times 12$ (= 30) or 20×5 (= 100) or 20×12 (= 240) or 20×13 (= 260)</p> <p>M1 (dep) for adding at least 3 areas found from correct methods (of no more than 5 faces) A1 cao</p> <p>OR</p> <p>M1 for $(5 + 12 + 13) \times 20$ or $\frac{1}{2} \times 5 \times 12$ (= 30) M1 (dep) for adding "$(5 + 12 + 13) \times 20$" to at least "$1 \times \frac{1}{2} \times 5 \times 12$" A1 cao</p> <p>Note: Sight of $\frac{1}{2} \times 5 \times 12 \times 20$ or 600 (ie a volume calculation) scores no marks</p>

Q9.

Question	Working	Answer	Mark	Notes
	<p>$\frac{9}{2} \times (12+18) = 135$ $135 \div 20 = 6.75$ (=7 bags) 7×4.99 OR $18 \times 9 - \frac{1}{2} (6 \times 9) = 135$ $135 \div 20 = 6.75$ (=7 bags) 7×4.99</p>	34.93	4	<p>M1 for $\frac{9}{2} \times (12+18)$ or $18 \times 9 - \frac{1}{2} (6 \times 9)$ or $9 \times 12 + \frac{1}{2} \times (18-12) \times 9$ or 135 seen M1 (dep) for '$135 \div 20$' or 6 or 7 seen M1 (dep on previous M1) for '6×4.99' or '7×4.99' A1 cao</p> <p>[SC: M1 for $(12 \times 9 + 6 \times 9) \div 20$ (= $162 \div 20$) or 8 or 9 seen M1 (dep) for '8×4.99' or '9×4.99' OR M1 for $(18 \times 9 - 6 \times 9) \div 20$ (= $108 \div 20$) or 5 or 6 seen M1 (dep) for '5×4.99' or '6×4.99']</p>

Q10.

Paper 1MA1: 1F			
Question	Working	Answer	Notes
		Correct diagram with layout and lengths	<p>M1 for changing to consistent units eg. $1000 \div 10$ or 40×10</p> <p>M1 for interpreting information and a process to fit tiles in floor area eg. may be seen in a sketch or a calculation</p> <p>C1 for a diagram to communicate a correct layout with lengths clearly identified</p>

Q11.

Question	Working	Answer	Mark	Notes
	Bottom / top is $5 \times 10 = 50$; $50 \times 2 = 100$; $280 - 100 = 180$ Other dimensions: $10 + 10 + 5 + 5 = 30$; $180 \div 30 =$	6	4	M1 recognition that the bottom/top is $5 \times 10 (= 50)$, 50 seen M1 for $280 - 2 \times "50" (= 180)$ M1 for " $180 \div$ "other dimensions" or valid attempt to find height using these dimensions A1 cao

Q12.

Question	Working	Answer	Mark	Notes
*	$500 \times 1000 \times 400 = 200\,000\,000$ $20 \times 50 \times 40 = 40\,000$ $200\,000\,000 \div 40\,000 = 5000$ OR $(500 \div 20) \times (1000 \div 50) \times (400 \div 40)$ $= 25 \times 20 \times 10 = 5000$	Proof	4	B1 for a correct unit conversion, could be seen on the diagram or in working M1 for $500 \times 1000 \times 400$ or $200\,000\,000$ or $20 \times 50 \times 40$ or $40\,000$ or $5 \times 10 \times 4$ or 200 or $0.2 \times 0.5 \times 0.4$ or 0.04 M1(dep) for ' $200\,000\,000$ ' \div ' $40\,000$ ' C1 for fully correct working leading to final answer of 5000 OR B1 for a correct unit conversion, could be seen on the diagram or in working M1 for $(500 \div 20)$ or $(1000 \div 50)$ or $(400 \div 40)$ or at least two of 25, 20, 10 seen M1(dep) for ' 25 ' \times ' 20 ' \times ' 10 ' C1 for fully correct working leading to final answer of 5000

Q13.

Paper 1MA1: 1F			
Question	Working	Answer	Notes
		48	P1 begins to work with rectangle dimensions eg $l+w=7$ or $2 \times l+w (=11)$ C1 shows a result for a dimension eg using $l=4$ or $w=3$ P1 begins process of finding total area eg $4 \times "3" \times "4"$ A1 cao

Q14.

Paper 1MA1: 1F			
Question	Working	Answer	Notes
		explanation	<p>M1 works with volume eg 240000</p> <p>M1 uses conversion 1 litre = 1000 cm³</p> <p>M1 uses 8000 eg vol ÷ 8000 (=30)</p> <p>M1 uses "30" eg "30" × 2.50</p> <p>C1 for explanation and 75 stated</p>
			<p>begins working back eg 70÷2.50</p> <p>uses conversion 1 litre = 1000 cm³</p> <p>uses 8000 eg "28"× 8000 (=224000)</p> <p>works with vol. eg 224000</p> <p>for explanation with 240000 and 224000</p>