

Name: _____

Higher Unit 11 topic test

Date:

Time: 50 minutes

Total marks available: 45

Total marks achieved: _____

Questions

Q1.

$$\text{Pressure} = \frac{\text{force}}{\text{area}}$$

Find the pressure exerted by a force of 900 newtons on an area of 60cm².
Give your answer in newtons/m².

..... newtons/m²

(Total for question = 2 marks)

Q2.

Mrs Jennings shares £770 between her two sons, Pete and Tim.
She shares the money in the ratio of her sons' ages.

The combined age of her two sons is 66 years.
Pete is 6 years younger than Tim.

Work out how much money each son gets.
You must show all your working.

Pete £

Tim £

(Total for Question is 5 marks)

Q3.

160 cm of gold wire has a weight of 17.8 grams.

Work out the weight of 210 cm of the gold wire.

.....
(Total for Question is 3 marks)

Q4.

y is directly proportional to x .

When $x = 600$, $y = 10$

(a) Find a formula for y in terms of x .

$y = \dots\dots\dots$
(3)

(b) Calculate the value of y when $x = 540$

$y = \dots\dots\dots$
(1)

(Total for Question is 4 marks)

Q5.

Bella invests £5000 in an account for two years.
The account pays 3% compound interest per annum.

Bella has to pay 20% tax on the interest earned each year.
This tax is taken from the account at the end of each year.

How much money will Bella have in her account at the end of the two years?

(Total for question = 4 marks)

Q6.

Peter has £20 000 to invest in a savings account for 2 years.

He finds information about two savings accounts.

<p style="text-align: center;">Bonus Saver</p> <p style="text-align: center;">Compound interest</p> <p style="text-align: center;">4% for the first year then 1.5% each year</p>

<p style="text-align: center;">Fixed Rate</p> <p style="text-align: center;">Compound interest</p> <p style="text-align: center;">2.5% each year</p>

Peter wants to have as much money as possible in his savings account at the end of 2 years.

Which of these savings accounts should he choose?

(Total for question = 4 marks)

Q7.

Asif is going on holiday to Turkey.

The exchange rate is $\text{£}1 = 3.5601$ lira.

Asif changes $\text{£}550$ to lira.

(a) Work out how many lira he should get.

Give your answer to the nearest lira.

..... lira
(2)

Asif sees a pair of shoes in Turkey.

The shoes cost 210 lira.

Asif does not have a calculator.

He uses $\text{£}2 = 7$ lira to work out the approximate cost of the shoes in pounds.

(b) Use $\text{£}2 = 7$ lira to show that the approximate cost of the shoes is $\text{£}60$

(2)

(c) Is using $\text{£}2 = 7$ lira instead of using $\text{£}1 = 3.5601$ lira a sensible start to Asif's method to work out the cost of the shoes in pounds?

You must give a reason for your answer.

.....
.....
(1)

(Total for question = 5 marks)

Q8.

Katy invests £2000 in a savings account for 3 years.

The account pays compound interest at an annual rate of

2.5% for the first year

$x\%$ for the second year

$x\%$ for the third year

There is a total amount of £2124.46 in the savings account at the end of 3 years.

(a) Work out the rate of interest in the second year.

.....
(4)

Katy goes to work by train.

The cost of her weekly train ticket increases by 12.5% to £225

(b) Work out the cost of her weekly train ticket before this increase.

£.....
(2)

(Total for question = 6 marks)

Q9.

The diagram shows a solid triangular prism.

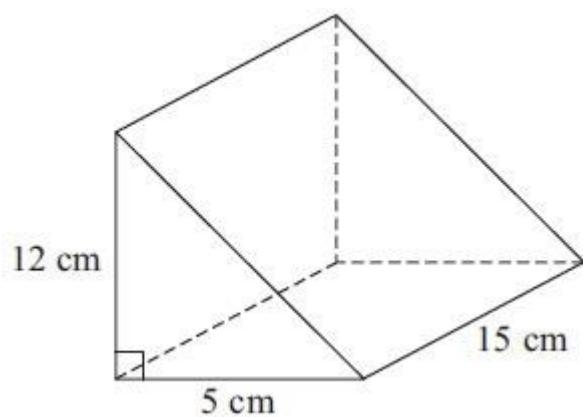

Diagram **NOT**
accurately drawn

The prism is made from metal.
The density of the metal is 6.6 grams per cm^3 .

Calculate the mass of the prism.

(Total for Question is 3 marks)

Q10.

A frustum is made by removing a small cone from a large cone as shown in the diagram.

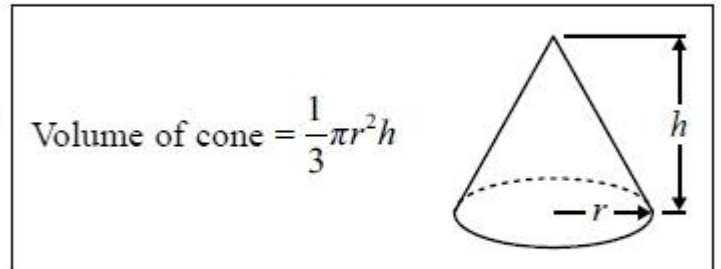
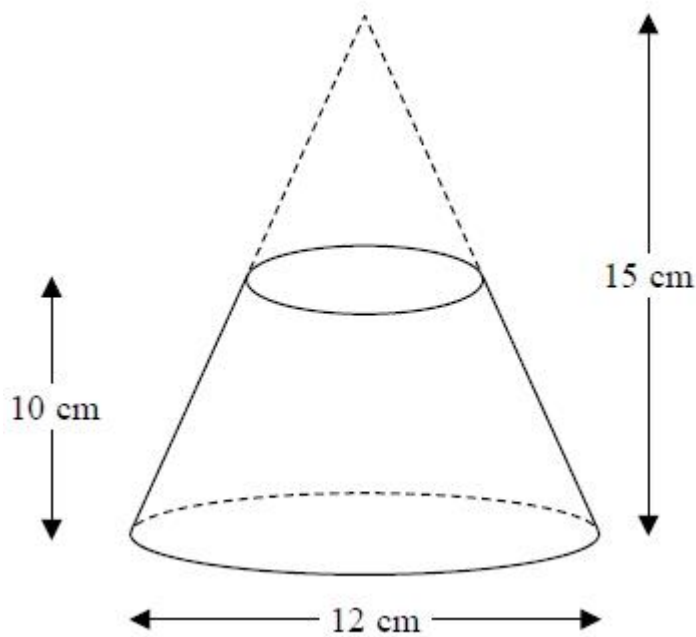

The frustum is made from glass.
The glass has a density of 2.5 g / cm^3

Work out the mass of the frustum.
Give your answer to an appropriate degree of accuracy.

..... g

(Total for question = 5 marks)

Q11.

The diagram shows a solid wooden sphere.

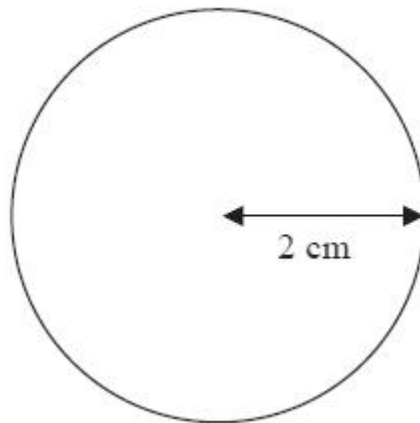

Diagram **NOT**
accurately drawn

The radius of the sphere is 2 cm.

The mass of the sphere is 45 grams.

Wood will float on the Dead Sea only when the density of the wood is less than 1.24 g/cm^3 .

Will this wooden sphere float on the Dead Sea?

(Total for Question is 4 marks)

Examiner's Report

Q1.

No Examiner's Report available for this question

Q2.

Most candidates were able to gain 2 marks here for finding the ages as 30 and 36. The better candidates went on to simplify 30:36 to give 5:6 thus giving easier calculations and most of these went on to score full marks. Those who attempted to divide 770 by 66 often gave their answer to this as 11 remainder 44 or 11.6 or sometimes just 11. Whilst many were then able to score the next method mark for multiplying their answer to the division by 30 or 36 they lost the accuracy mark for the final answers due to premature rounding.

Q3.

Many candidates clearly did not understand the concept of density. A common error was to start with $160 \div 17.8$; the vast majority of candidates who did this failed to gain any marks as they went onto multiply their result by 210. Candidates who carried out the correct method in two steps frequently lost marks due to premature rounding.

The majority of candidates found the weight of 1 cm then scaled this up to find the weight of 210 cm. However, some candidates successfully found the weight of either 50 cm (the difference in the two lengths) or 10 cm and used these weights to give the right answer.

A common error was to state that the weight of 10cm was 1.78g. A relatively high proportion of candidates lost the accuracy mark when using the latter method, however. Candidates who used repeated division to get 80,40 20 and 10 often lost marks due to premature rounding.

Q4.

In part (a) a significant number were able to understand that y was proportional to x and continued to write $y=kx$, usually writing $10=k \times 600$. Completion of this was frequently flawed, leading to $60x$ rather than $x/60$. The mark in part (b) was usually gained, in many cases using their flawed equation (used correctly).

Q5.

No Examiner's Report available for this question

Q6.

Those who chose to work with multipliers regularly failed to score in this question, mainly due to a poor choice of multiplier, for example 0.4 rather than 0.04, or combining the 4% and 1.5%. 2.5^2 was also seen regularly. Many chose to use simple interest methods and therefore gained few marks, if any. Those who recognised this as compound interest were usually able to work out a correct figure for one of the banks, but both calculated correctly was rare.

Q7.

No Examiner's Report available for this question

Q8.

No Examiner's Report available for this question

Q9.

The volume calculation was frequently incorrect with the formula for the volume of a cuboid being calculated rather than the volume of the given triangular prism. The other common error was to divide, rather than multiply, the volume by the density to obtain the mass of the prism. Some candidates attempted to work out the surface area or find the sum of all the edges; such incorrect methods gained no marks.

Q10.

No Examiner's Report available for this question

Q11.

Even though the formula to find the volume of a sphere is given on the formula sheet, many used alternative formulae, often formulae for finding area. All methods using area gained no marks at all. Many students working with the correct volume and subsequent density failed to score the final mark with an incomplete conclusion. Students here were required to compare their calculated density to that given.

Mark Scheme

Q1.

Paper 1MA1: 1H			
Question	Working	Answer	Notes
		150 000	M1 $60 \div 100^2$ or $900 \div 60$ or $900 \div "60"$ A1

Q2.

Question	Working	Answer	Mark	Notes
	$66 \div 2 = 33 \pm (6 \div 2)$ $P = 30$ and $T = 36$ Ages = $30 : 36 = 5 : 6$ $770 \div 11 = 70$ each part $5 \times 70 = \text{£}350$ $6 \times 70 = \text{£}420$	 350 420	5	M1 $66 \div 2 = 33 \pm (6 \div 2)$ or $(66-6) \div 2$ or for at least 3 trials with a total of 66 or a difference of 6 or for $x + x + 6 = 66$ or $x + x - 6 = 66$ oe A1 for 30 and 36 seen or 5 and 6 oe M1 for $770 \div '11'$ or $770 \div 66$ M1 for ' $770 \div 66 \times '30'$ ', where '30' is a ft from their previous answer or ' $770 \div 66 \times '36'$ ', where '36' is a ft from their previous answer or ' $770 \div 11 \times 5$ ' or ' $770 \div 11 \times 6$ ' oe A1 for $P = 350$ and $T = 420$

Q3.

Question	Working	Answer	Mark	Notes
	$17.8 \div 160 \times 210 =$ $0.11125 \times 210 =$ 23.3625 g OR $210 \div 160 \times 17.8 =$ $1.3125 \times 17.8 =$ 23.3625 g OR $210 - 160 (=50)$ $\frac{17.8}{160} \times$ $'50' (=5.5625)$ $17.8 + 5.5625$	23.3(625)	3	M1 $17.8 \div 160 (=0.11125)$ or $17.8 \times 210 (=3738)$ or $210 \div 160 (=1.3125)$ M1 (dep) ' 0.11125 ' $\times 210$ or ' 3738 ' $\div 160$ or ' 1.3125 ' $\times 17.8$ A1 for answer in range 23.3 - 23.4 OR M1 for $\frac{17.8}{160} \times (210-160) (=5.5625)$ M1 (dep) for $17.8 + '5.5625'$ A1 for answer in range 23.3 - 23.4 OR M1 for correct method to find weight of 2 cm or 5 cm or 10 cm M1 (dep) for complete method A1 for answer in range 23.3 - 23.4

Q4.

Question	Working	Answer	Mark	Notes
(a)	$y = kx$ $10 = 600k$ $k = 10 \div 600 = \frac{1}{60}$	$y = \frac{1}{60}X$	3	M2 for $10 = k \times 600$ oe or $10 = \frac{600}{k}$ oe or $k = \frac{1}{60}$ (M1 for $y=kx$ or $y = \frac{x}{k}$ or $y \propto x$, k any letter or value) A1 for $y = \frac{1}{60} x$ oe SC: B2 for $60y = x$ NB: for $1/60$ accept 0.016 to 0.017 B1 for 9 or 8.6 to 9.2 or ft 540 \times "k"
(b)	$y = x \div 60 = 540 \div 60 =$	9	1	

Q5.

Question	Working	Answer	Mark	AO	Notes
		£5242.88	P	3.1d	P1 for a correct first step in the process, e.g. $5000 \times 0.03 (= 150)$ or $3 \times 0.8 = 2.4\%$
			P	3.1d	P1 for a correct process in finding the effect of the 20% tax on interest (i.e. "150"), e.g. "150" $\times 0.8 (= 120)$ or 5000×1.024
			P	3.1d	P1 (dependent on previous P marks) for a fully complete and correct process to find balance after 2 years, e.g. $(5000 + "120") + (5000 + "120") \times 0.03 \times 0.8$ or $5000 \times (1.024)^2$
			A	1.3b	A1 cao

Q6.

PAPER: IMA0_2H					
Question	Working	Answer	Mark	Notes	
*	$1.025^2 = 1.050625$ 1.04×1.015 $= 1.0556$	Bonus Saver with correct comparable values	4	M1 for a method to calculate 4% or 2.5% of 20000 (= 800 or 20800 or 500 or 20500) M1 for a method to calculate using a compound interest method, eg 1.025^2 oe or 1.04 followed by 1.015 oe A1 for 1.050625 or 1.0556 or 10556 or 556 or 21112 or 21012.5 or 1112 or 1012.5 C1 for a correct decision in a statement with two correct comparable values. NB all final money values can be rounded or truncated to nearest integer or left unrounded.	

Q7.

Paper 1MA1: 3H			
Question	Working	Answer	Notes
(a)	550×3.5601	1958	M1 550×3.5601 A1
(b)	$210 \div 7 \times 2 = 30 \times 2$ Or $60 \div 2 = 30$ and $30 \times 7 = 210$	Shown	M1 For correct method to convert cost in UK to lira or vice versa, using Asif's approximation C1 Shown with correct calculations
(c)		Correct evaluation	C1 For an evaluation eg. It is a sensible start to the method because he can do the calculations without a calculator and 3.5 lira to the £ is a good approximation

Q8.

Paper 1MA1: 2H			
Question	Working	Answer	Notes
(a)		1.8%	P1 for start to process eg. $2000 \times 1.025 (= 2050)$ P1 for process to use all given information eg. " 2050 " $\times m^2 = 2124.46$ or " 2050 " $\times \left(1 + \frac{x}{100}\right)^2 = 2124.46$ P1 for process to find their unknown eg $m = \sqrt{\frac{2124.46}{2050}} (= 1.01799\dots)$ A1 for 1.79% – 1.8 %
(b)		200	M1 $225 \div 1.125$ oe A1

Q9.

Question	Working	Answer	Mark	Notes
	Volume = $\frac{5 \times 12}{2} \times 15$ Mass = $\frac{5 \times 12}{2} \times 15 \times 6.6$	2970	3	M1 $\frac{5 \times 12}{2} \times 15$ (=450) M1 (dep on 1 st M1) '450'×6.6 A1 cao SC: If no marks awarded then award B1 for an answer of 5940

Q10.

Paper 1MA1: 2H			
Question	Working	Answer	Notes
		1361	P1 process using similar triangles to find base of small cone eg. 4 cm used as diameter or 2 cm used as radius P1 process to find volume of one cone P1 complete process to find volume of frustum P1 complete process to find mass or 1360 – 1362 A1 1361 or 1360 or 1400

Q11.

Paper: 5MB3H_01				
Question	Working	Answer	Mark	Notes
*		No with reason	4	M1 for $\frac{4}{3} \times \pi \times 2^3$ (=33.51...) M1 for 45 ÷ "volume" A1 for 1.3 – 1.4 C1 (dep on M1) for No and eg. 1.34 > 1.24 OR M1 for (volume =) 45 ÷ 1.24 (= 36.29...) oe M1 for (r^3 =) "36.29..." ÷ ($\frac{4}{3} \times \pi$) oe A1 for 8.6 – 8.7 C1 (dep on M1) for No and eg. 8.6... > 8